

MEMORANDUM TO: Project Engineers  
Project Design Engineers

FROM: T. K. Koch, P.E.  
State Structures Engineer

DATE: December 19, 2016

SUBJECT: Construction Elevations

At the request of the Construction Unit, the details for reporting Construction Elevations have been revised.

The following replaces Section 6.2.2.9 in the Design Manual:

---

Construction Elevations are used to set deck forms and screeds during the construction of concrete bridge decks and approach slabs. For all bridges except cored slabs and box beams, compute Construction Elevations during the final plan preparation stage. Construction Elevations shall consist of bottom of slab elevations, approach slab elevations, and any necessary header elevations. Prepare one office copy of Construction Elevations to be retained with the bridge design files and two field copies to be furnished to the Resident Engineer or other appropriate Division personnel.

Provide Preliminary Header Elevations to the Area Construction Engineer during preliminary plan preparation for bridges with geometric features that create difficult operating conditions for the screed.

### **Bottom of Slab Elevations**

Bottom of slab elevations above the centerline of each girder are used to set the forms for the buildups. Provide bottom of slab elevations for all interior and exterior beams/girders at the following intervals:

- For beams or girders with bearing-to-bearing lengths less than or equal to 100 feet, 20<sup>th</sup> points between centerlines of bearings.
- For beams or girders with bearing-to-bearing lengths greater than 100 feet and less than or equal to 200 feet, 40<sup>th</sup> points between centerlines of bearings.
- For beams or girders with bearing-to-bearing lengths greater than 200 feet, 60<sup>th</sup> points between centerlines of bearings.

At each bottom of slab point along the exterior girders, provide the following information:



- Offset distance between the centerline of exterior girder and the outside edge of superstructure, measured normal to the girder centerline.
- Elevation difference between the bottom of slab at the exterior girder and the bottom of slab at the outside edge of superstructure (i.e. bottom of overhang), shown as positive for an increase in elevation from bottom of slab to bottom of overhang, and negative for a decrease in elevation from bottom of slab to bottom of overhang.

For stage-constructed bridges with temporary overhangs in closure bays, do not provide the elevation difference between the bottom of slab and the bottom of closure pour joint.

For heavily skewed spans, if the offset from the exterior girder intersects the centerline of bearing before intersecting the outside edge of superstructure, report only the bottom of slab elevation.

Vertical curve and superelevation ordinates are used during the design and plan preparation stages and are not needed for setting deck forms. Do not report vertical curve and superelevation ordinates in Construction Elevations.

When preparing Construction Elevations reports, locate the appropriate detail based on end bent type/joint type and skew within the Construction Elevations Sketch MicroStation file titled "CE2" available on the Structures Management Unit web page. Revise the sketch as instructed in CE2 and include with the office and field copies of the Construction Elevations. See [Figure 6-62](#). The sketch is detailed for a span on a tangent alignment and with parallel end bents and bents. For a span on a curved alignment, add a note to the sketch to designate the radius and direction of curvature of the survey line (or control line for dual bridges) as shown in [Figure 6-62](#). Do not modify the sketch to depict the actual curvature. For a span with non-parallel end bents and bents, modify the sketch to approximately depict the difference in skew.

### **Approach Slab Elevations**

Provide top of slab elevations for the left and right outside edges of each approach slab. Include elevations at the following points along each outside edge:

- The roadway end of approach slab; i.e. Beginning of Approach Slab near End Bent 1, End of Approach Slab near End Bent 2.
- The bridge end of approach slab; centerline of joint at an end bent with an expansion joint (non-integral end bent) or construction joint between the approach slab and end bent diaphragm (integral end bent).
- For an approach slab adjacent to an integral end bent or an end bent with an expansion joint type other than an Expansion Joint Seal (i.e. curb throughout the entire length) include an elevation point at the midpoint between the roadway and bridge ends. Include additional points at 4 foot intervals from the midpoint toward the roadway and bridge ends.
- For an approach slab adjacent to an end bent with an Expansion Joint Seal (i.e. barrier rail or end post extending from the bridge onto the approach slab for a portion of the length) include an elevation point at the transition point between the barrier rail or end post and

curb; locate this point at the outside edge of the rail or end post. Include additional points at 4 foot intervals from the transition point toward the roadway and bridge ends.

When preparing Construction Elevations reports, locate the appropriate detail based on end bent type/joint type and skew within the Construction Elevations Sketch MicroStation file titled "CE2" available on the Structures Management Unit web page. Revise the sketch as instructed in CE2 and include with the office and field copies of the Construction Elevations. See [Figure 6-63](#). The sketch is detailed for an approach slab on a tangent alignment and with parallel roadway and bridge ends. For an approach slab on a curved alignment, add a note to the sketch to designate the radius and direction of curvature of the survey line (or control line for dual bridges) as shown in [Figure 6-63](#). Do not modify the sketch to depict the actual curvature. For an approach slab with non-parallel roadway and bridge ends (such as an approach slab adjacent to rigid concrete approach pavement), modify the sketch to approximately depict the difference in skew. Label the stations along the outside edges and the survey line (or control line for dual bridges) as shown in [Figure 6-63](#).

### **Preliminary Header Elevations**

Bridges with two or more of the following geometric features can result in bridge deck surfaces that are difficult to finish with a screed.

- Skew  $\leq 75^\circ$  or  $\geq 105^\circ$
- Vertical curve on the superstructure
- Transitioning superelevation
- Crowned section (e.g. normal crown)

When the Roadway plans detail two or more of these features, coordinate with Roadway Design and the Area Construction Engineer to mitigate the constructability concerns. For bridges that must be designed with two or more of these features, compute top of slab elevations for each span along the following end-of-span headers:

- Centerline of joint at an end bent with an expansion joint (non-integral end bent) or construction joint between the approach slab and end bent diaphragm (integral end bent).
- Centerline of joint at an interior bent with an expansion joint (non-continuous bent) or control line at an interior bent without an expansion joint (continuous bent).

Include headers at quarter points measured along the survey line (or control line for dual bridges) between the end-of-span headers. If the skew angles between two adjacent end-of-span headers are the same, use the same skew at each quarter point within the span. If the skew angles between two adjacent end-of-span headers are different, interpolate to determine the skews at each quarter point within the span.

Provide top of slab header elevations at the grade point and 2 foot intervals normal to the survey line (or control line for dual bridges) between the grade point and the left and right outside edges of superstructure. Along with these intervals, include any offset within the typical section for a change or break in superelevation, including traffic faces of barrier rails or parapets.

When preparing Preliminary Header Elevations reports, locate the appropriate detail based on end bent type/joint type and skew within the Construction Elevations Sketch MicroStation file titled “CE1” available on the Structures Management Unit web page. Revise the sketch as instructed in CE1 and include with the Preliminary Header Elevations. See [Figure 6-64](#). The sketch is detailed for a span on a tangent alignment and with parallel end bents and bents. For a span on a curved alignment, add a note to the sketch to designate the radius and direction of curvature of the survey line (or control line for dual bridges) as shown in [Figure 6-64](#). Do not modify the sketch to depict the actual curvature. For a span with non-parallel end bents and bents, modify the sketch to approximately depict the difference in skew.

Submit this information, along with the Preliminary General Drawing, to the Area Construction Engineer for review and comments. Do not include this information in the office and field copies of the Construction Elevations.

### **Additional Header Elevations**

Consult with the Area Construction Engineer to establish when a longitudinal screed is required. If a longitudinal screed is required on a project, provide top of slab elevations along each transverse construction joint in addition to the end-of-span headers described in Preliminary Header Elevations.

When preparing Construction Elevations reports, locate the appropriate detail based on end bent type/joint type and skew within the Construction Elevations Sketch MicroStation file titled “CE2” available on the Structures Management Unit web page if a longitudinal screed is required. Revise the sketch as instructed in CE2 and include with the office and field copies of the Construction Elevations. The sketch is detailed for a span on a tangent alignment and with parallel end bents and bents. For a span on a curved alignment, add a note to the sketch to designate the radius and direction of curvature of the survey line (or control line for dual bridges). Do not modify the sketch to depict the actual curvature. For a span with non-parallel end bents and bents, modify the sketch to approximately depict the difference in skew.

---

This policy is effective with the April 2017 letting. The Design Manual and Design Manual Figures have been updated and are available on the Structures Management Unit website. Design Manual Figures 6-62, 6-62 M, 6-63, 6-63 M, 6-64, and 6-64 M have been revised and are attached. Design Manual Figures 6-65, 6-65 M, 12-19, 12-19 M, 12-20, and 12-20 M have been deleted.

Construction Elevations Sketches CE1 and CE2 have been created and are available on the SMU server at the following location:

- S:\Share\Construction Elevations Sketches

Construction Elevations Sketches CE1 and CE2 are also available on the SMU website at the following link:

- <https://connect.ncdot.gov/resources/Structures/Pages/Construction-Elevation-Sketches.aspx>

TKK/DCM/THC

Attachments:

Figure 6-62 (English)  
Figure 6-62 M (Metric)  
Figure 6-63 (English)  
Figure 6-63 M (Metric)  
Figure 6-64 (English)  
Figure 6-64 M (Metric)

cc: B. C. Hanks, P.E.  
E. B. Nelson, P.E.  
G. Muchane, P.E.  
L. Sylvester, P.E.  
W. McAbee, P.E., FHWA  
Division Bridge Program Managers  
Area Construction Engineers

FIGURE 6 - 62

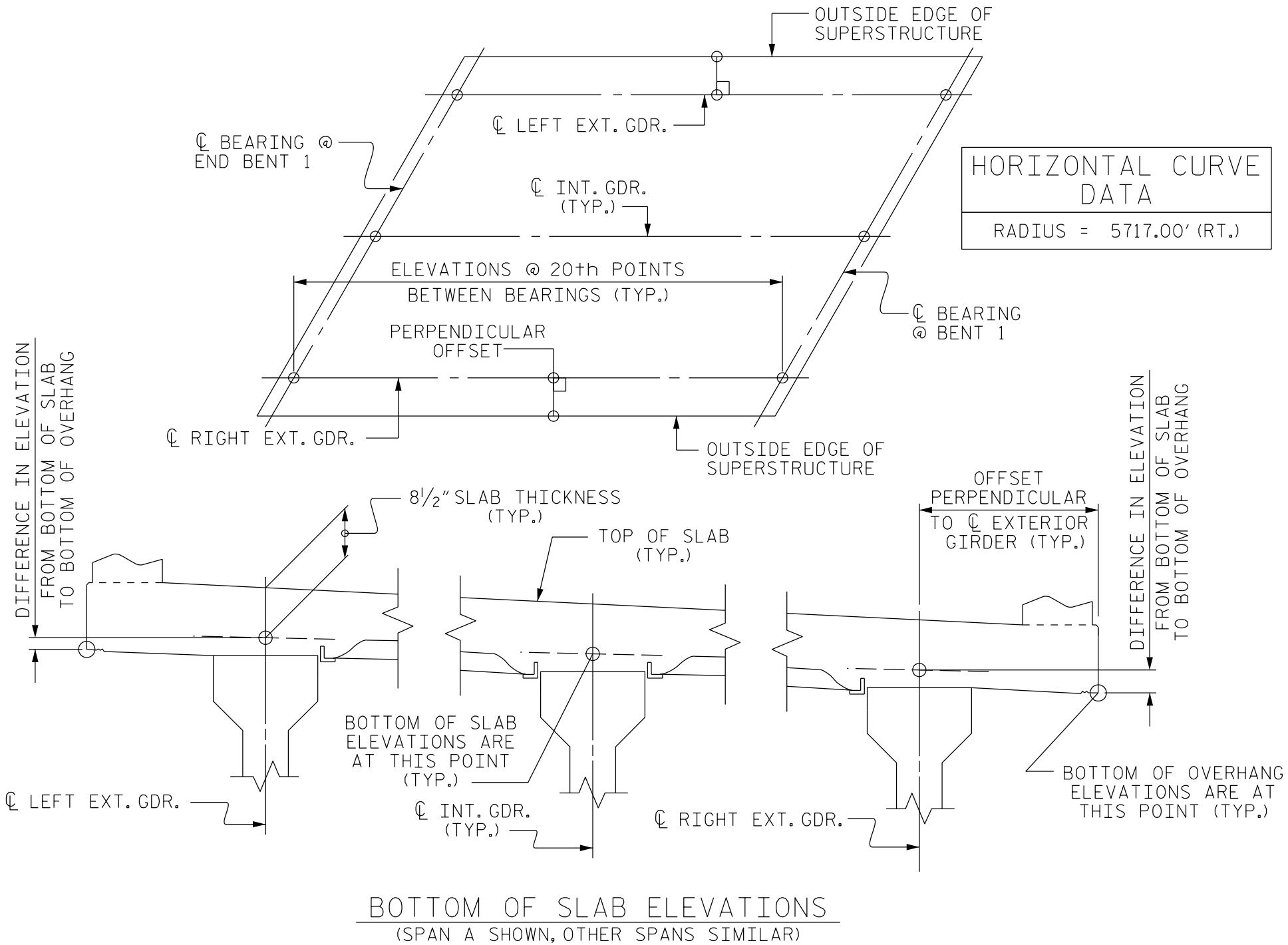

CONSTRUCTION ELEVATIONS SKETCH

EXAMPLE SKETCH FOR CONCRETE GIRDER BRIDGE ON A CURVE

FIGURE 6 - 62 M

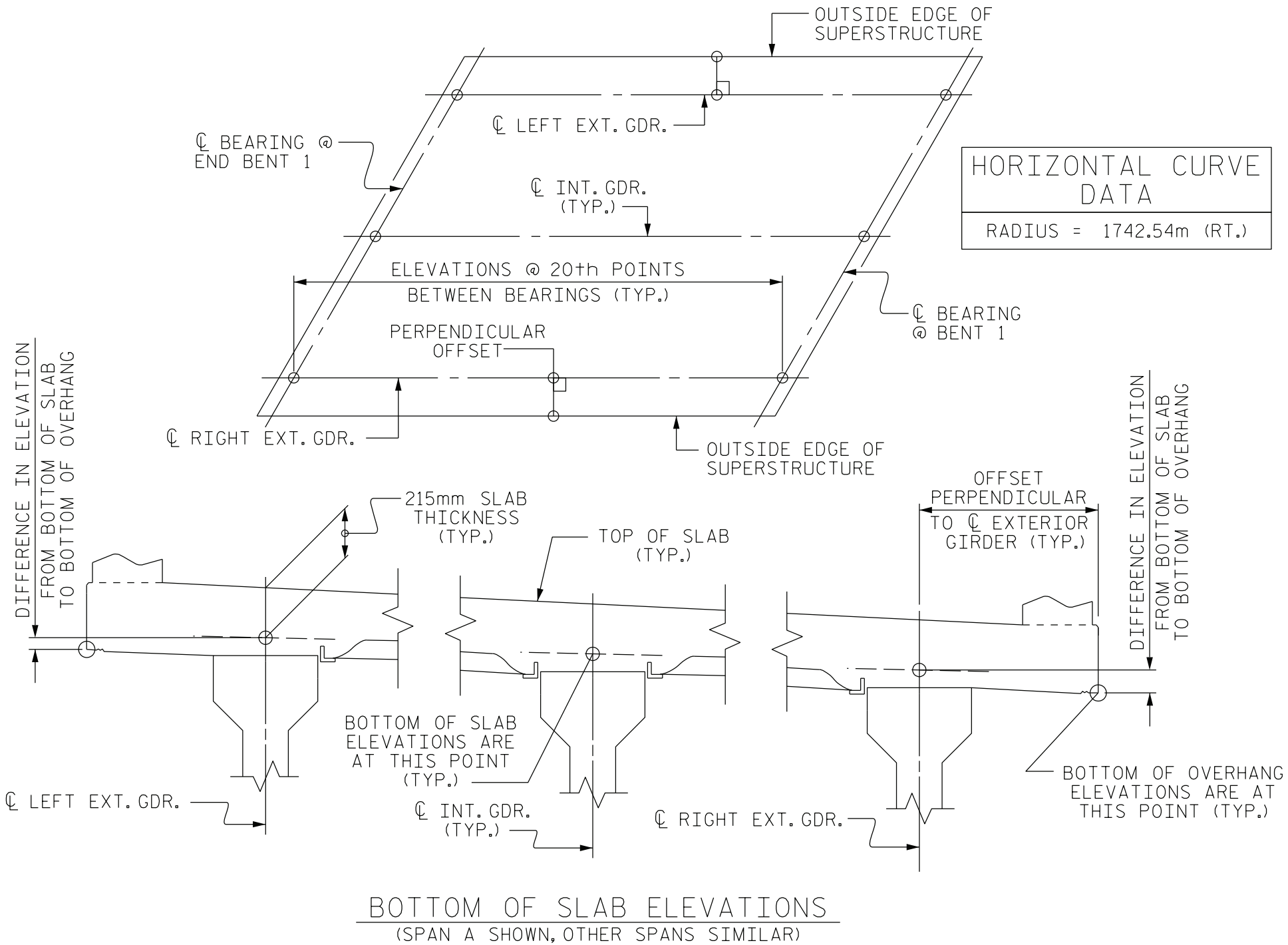

CONSTRUCTION ELEVATIONS SKETCH

EXAMPLE SKETCH FOR CONCRETE GIRDER BRIDGE ON A CURVE

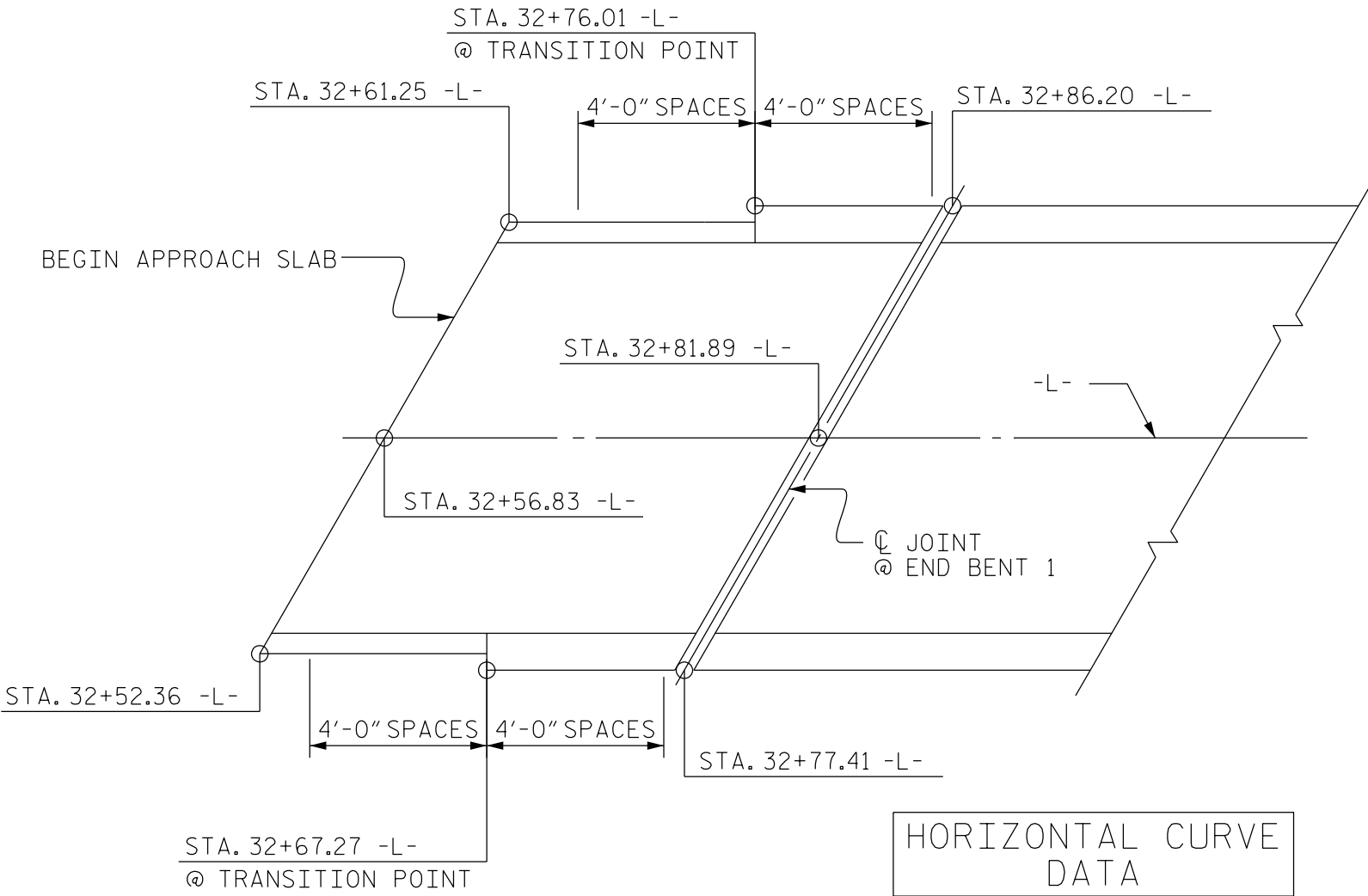

HORIZONTAL CURVE DATA
RADIUS = 5717.00' (RT.)

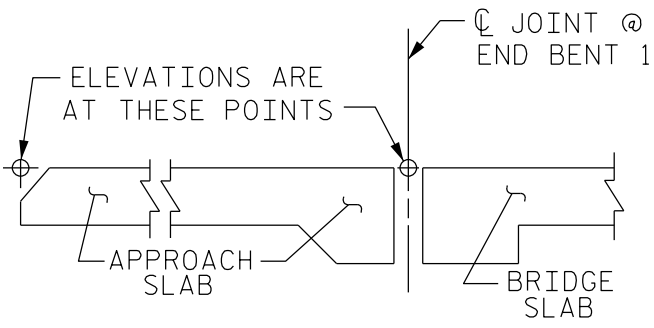

SECTION THRU SLABS

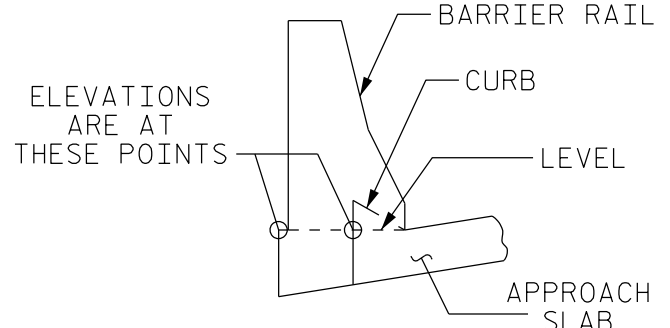

SECTION THRU CURB & BARRIER RAIL

APPROACH SLAB ELEVATIONS  
(APPROACH SLAB @ BEGINNING OF BRIDGE SHOWN)

CONSTRUCTION ELEVATIONS SKETCH  
EXAMPLE SKETCH FOR APPROACH SLAB ON CURVE  
WITH EXPANSION JOINT SEAL AT END BENT

**FIGURE 6 - 63**



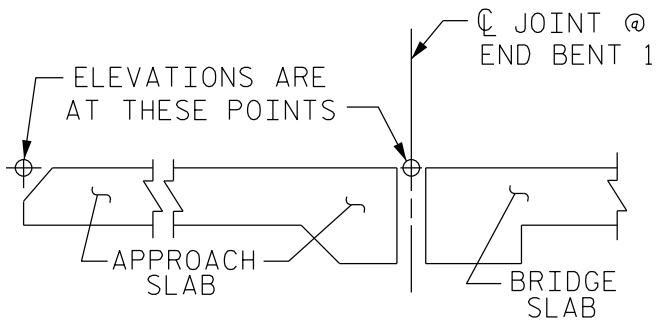
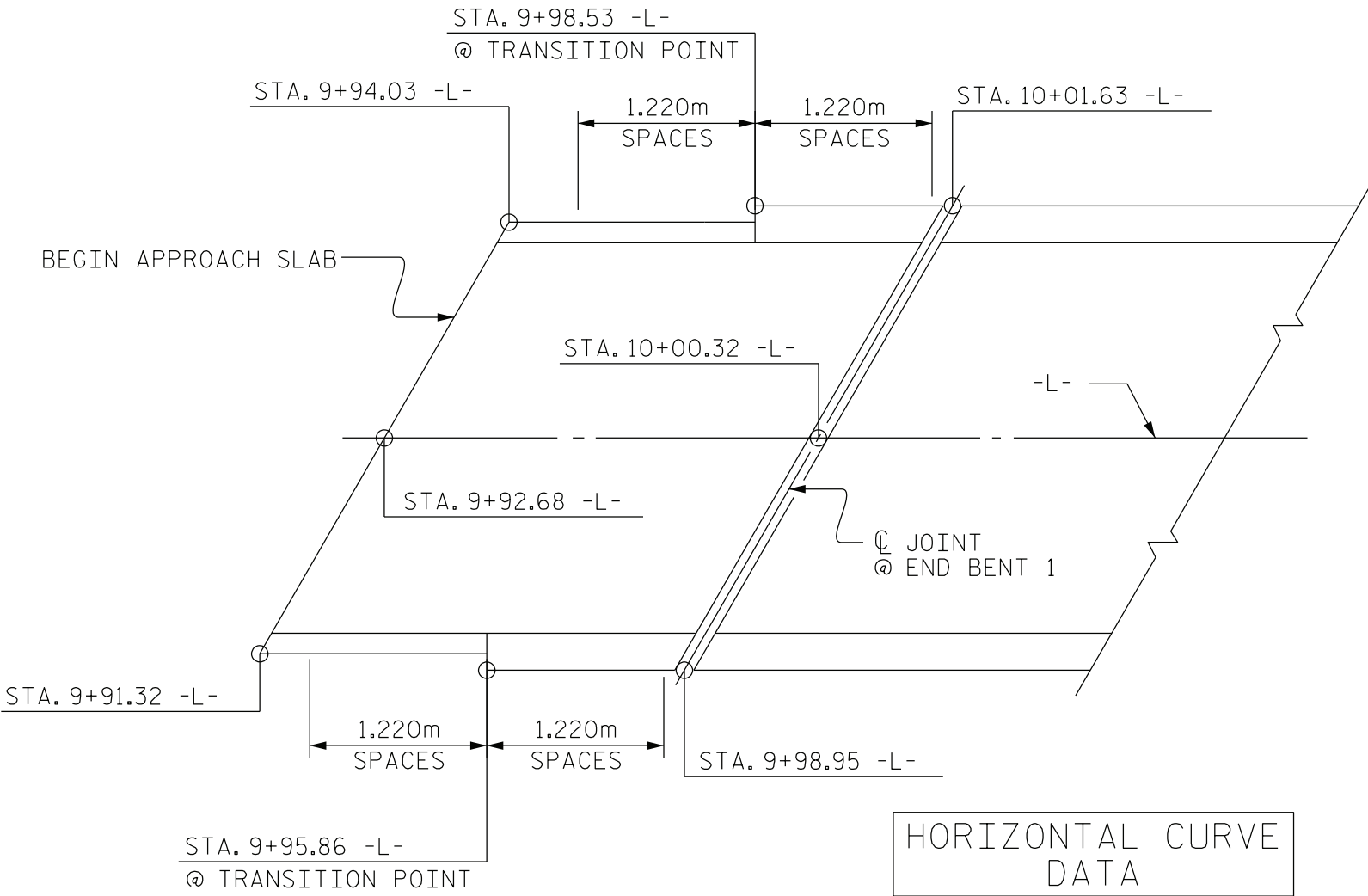

SECTION THRU SLABS

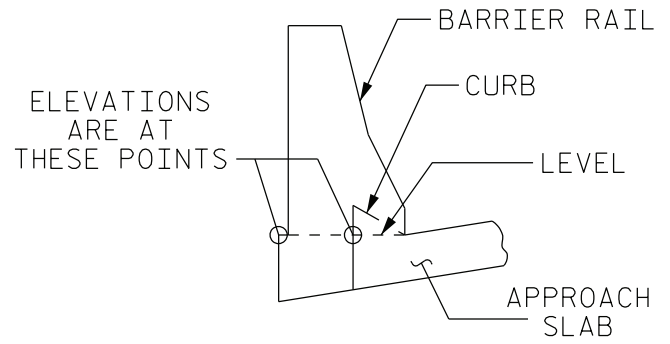

SECTION THRU CURB & BARRIER RAIL

APPROACH SLAB ELEVATIONS

(APPROACH SLAB @ BEGINNING OF BRIDGE SHOWN)

CONSTRUCTION ELEVATIONS SKETCH

EXAMPLE SKETCH FOR APPROACH SLAB ON CURVE WITH EXPANSION JOINT SEAL AT END BENT

**FIGURE 6 - 63 M**

HORIZONTAL CURVE  
DATA

RADIUS = 5717.00' (RT.)

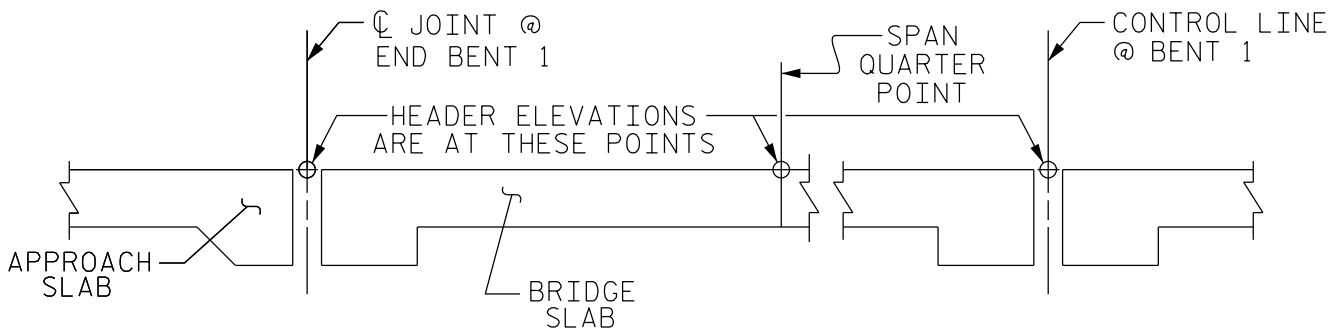
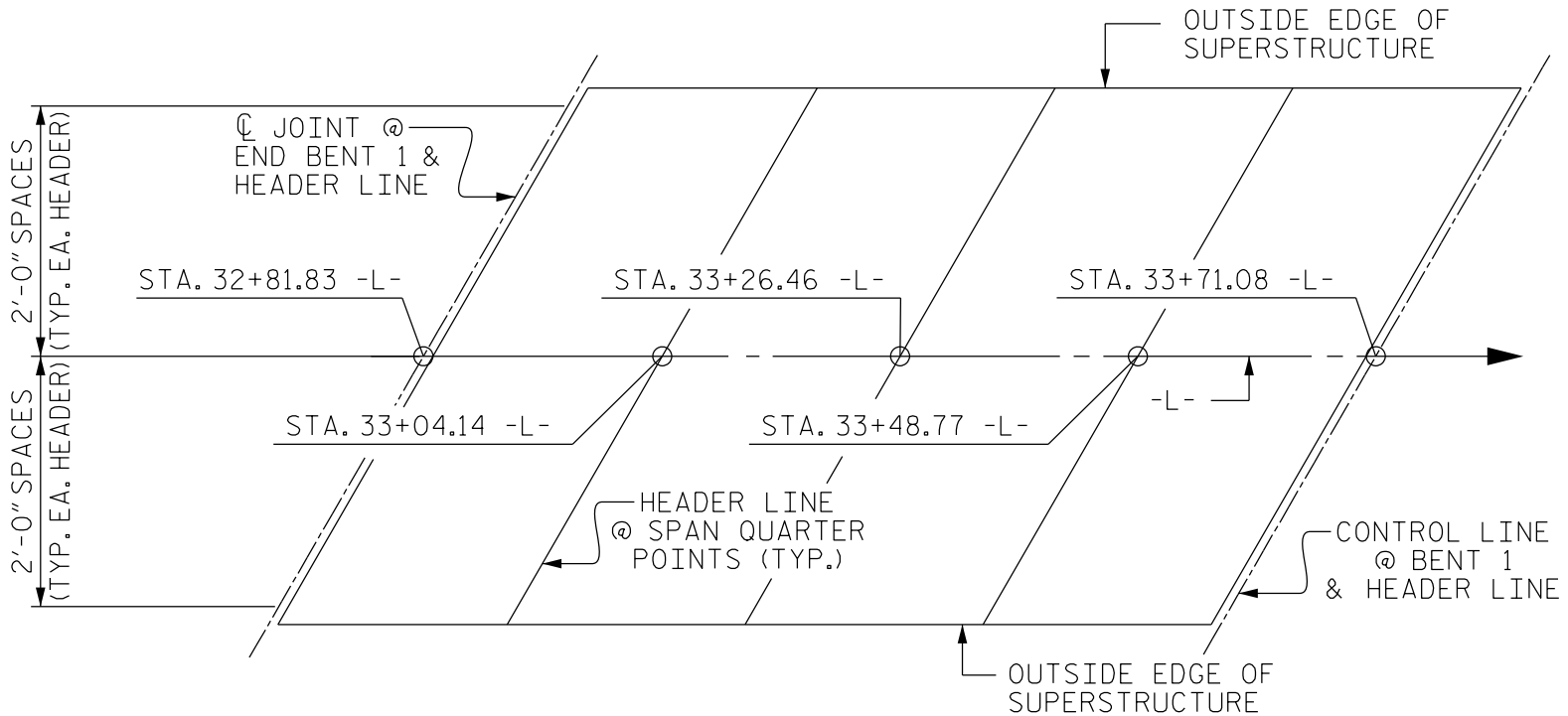

PRELIMINARY HEADER ELEVATIONS

(SPAN A SHOWN, OTHER SPANS SIMILAR)

CONSTRUCTION ELEVATIONS SKETCH

EXAMPLE SKETCH FOR BRIDGE ON A CURVE WITH  
EXPANSION JOINT AT END BENT AND CONTINUOUS AT BENT

FIGURE 6 - 64

HORIZONTAL CURVE DATA

RADIUS = 1742.54m (RT.)

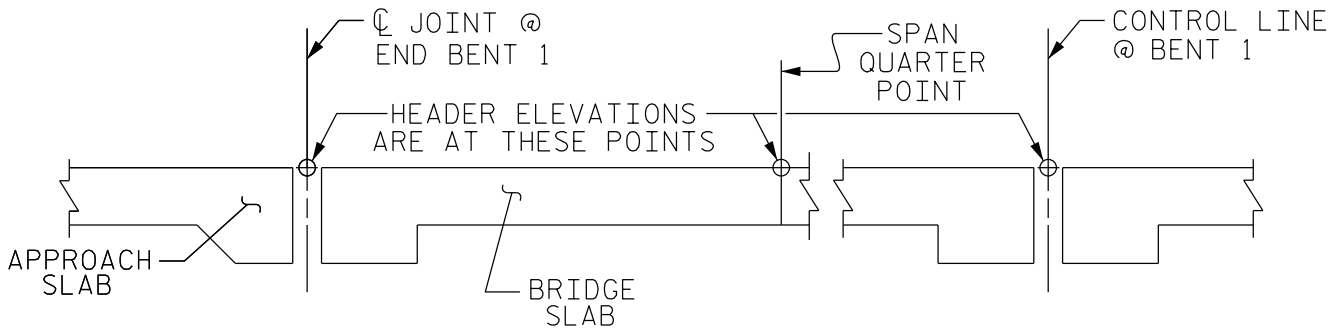
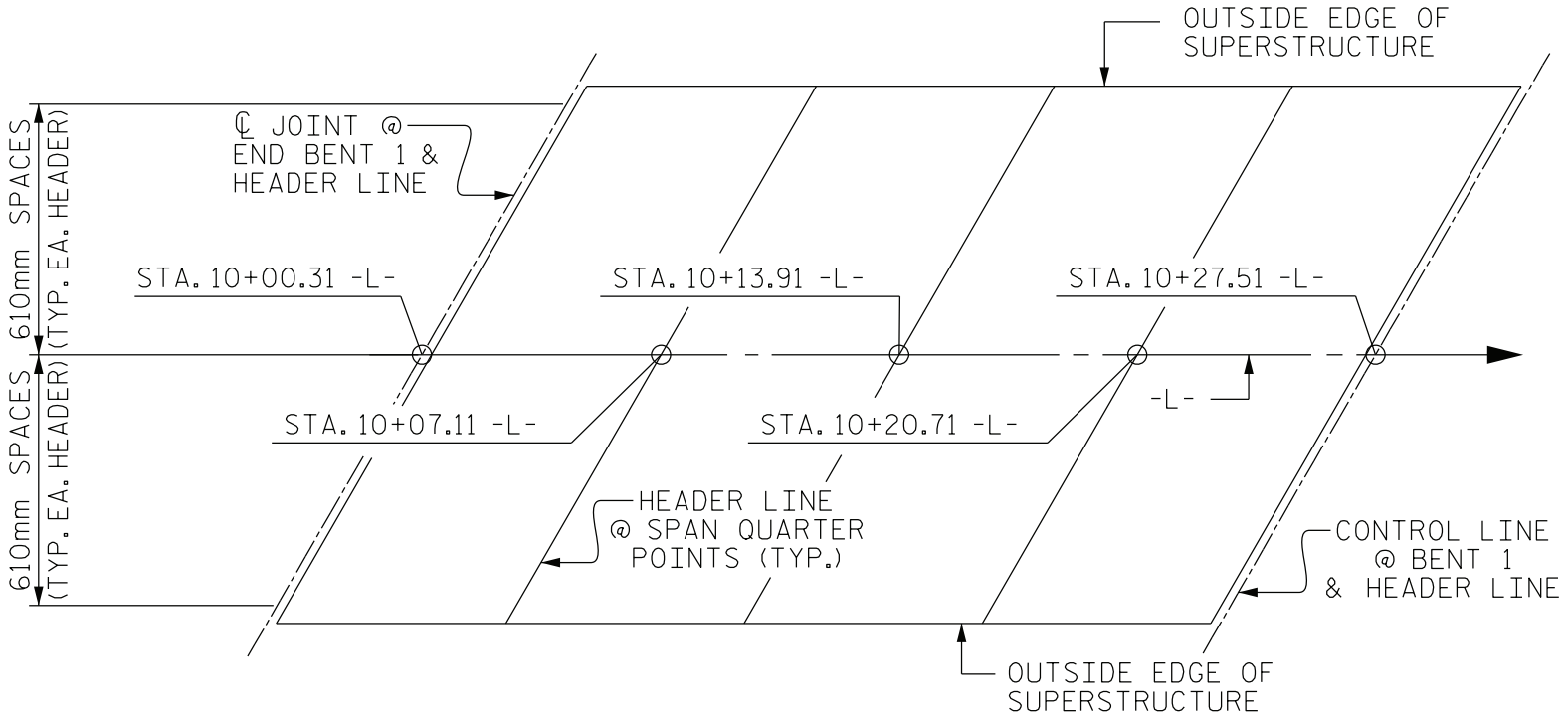

SECTION THRU SLABS

PRELIMINARY HEADER ELEVATIONS

(SPAN A SHOWN, OTHER SPANS SIMILAR)

CONSTRUCTION ELEVATIONS SKETCH

EXAMPLE SKETCH FOR BRIDGE ON A CURVE WITH EXPANSION JOINT AT END BENT AND CONTINUOUS AT BENT

**FIGURE 6 - 64 M**